

Automatic test on
rocker pins
for correct heat treatment
with **eddyliner® P 2**
and a **twin sorter**

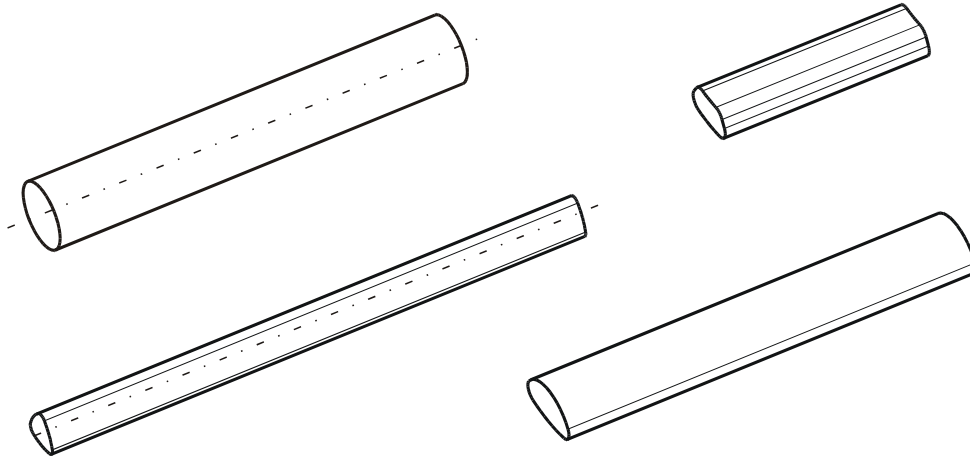

Test rate: max. 8.400 parts/h
Range of parts: \varnothing 3,3mm up to 5mm
Length: l 12,5mm up to 55mm
Varity of parts: 32 types



The parts are fed to the test system one after the other in a feeding hose and forwarded unmatched to the test coils by means of two friction wheels.

Change-over of the easily accessible test system to various part geometries is carried out within a very short time by means of change parts. Both NOK containers (red) are located behind the lockable front door and are protected from unauthorized access.

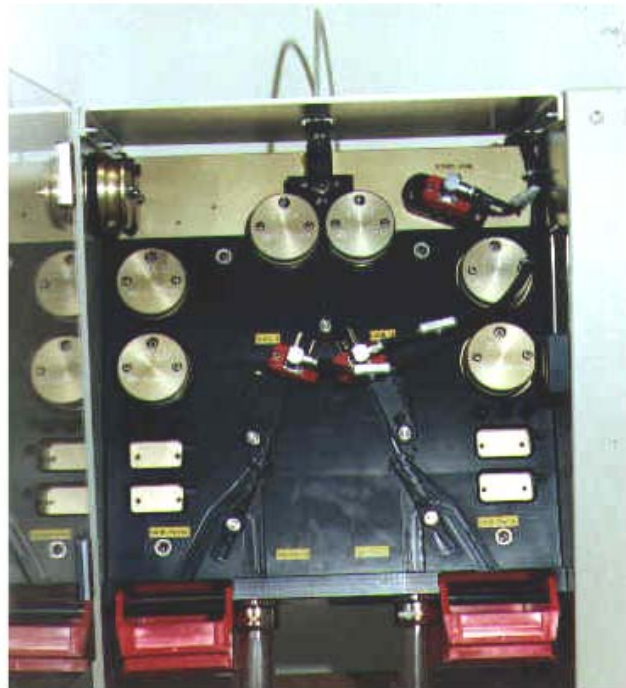

Due to the large wheels of the steel frame the test system can easily be brought to the place of operation. The dust-proof design grants a long operation in production without failure.